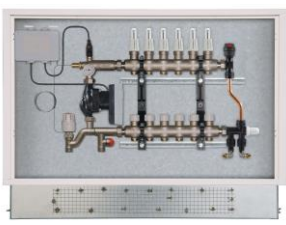
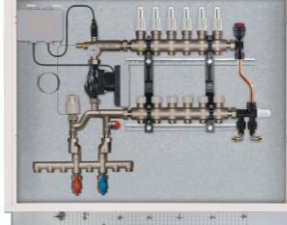
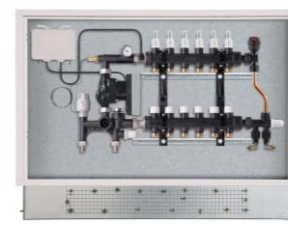
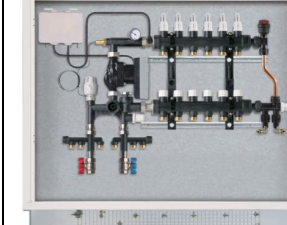

KILMA ECONBLOCK-RF

BRASS Control units		POLYMER Control units	
RF	RF-AT	RF	RF-AT
			
70X.06.50	70X.06.60	153X.06.50	153X.06.70

PRODUCTION RANGE

FIXED REGULATION	Number of high temperature ways*	Code				Number of low temperature ways**
		High-low water temperature distribution		Only low temperature water distribution		
		RF-AT in OTTONE	RF-AT in POLIMERO	RF in OTTONE	RF in POLIMERO	
	3 + 3	701.06.60	1531.06.70	701.06.50	1531.06.50	3 + 3
		702.06.60	1532.06.70	702.06.50	1532.06.50	4 + 4
		703.06.60	1533.06.70	703.06.50	1533.06.50	5 + 5
		704.06.60	1534.06.70	704.06.50	1534.06.50	6 + 6
		705.06.60	1535.06.70	705.06.50	1535.06.50	7 + 7
		706.06.60	1536.06.70	706.06.50	1536.06.50	8 + 8
		707.06.60	1537.06.70	707.06.50	1537.06.50	9 + 9
		708.06.60	1538.06.70	708.06.50	1538.06.50	10 + 10
		709.06.60	1539.06.70	709.06.50	1539.06.50	11 + 11
		709.12.60	1540.06.70	709.12.50	1540.06.50	12 + 12
Manifold A.T.		Yes	Yes	No	No	

* Required only for codes 70X.XX.60 and 153X.06.70, they are coupled with fittings (not included in the control unit) with a G 3/4" Euroconus thread (BRASS control units) or a W24.5 x 19F "Standard" RBM thread (POLYMER control units).

** The low temperature pipe manifolds have G 3/4" Euroconus connections and a diameter equal to 1" on the main way. The pipe fittings of the underfloor system and (where present) for the connections to the HT (high temperature) circuit, are supplied separately.

1 DESCRIPTION

THE PURPOSE

The *RBM Kilma Econblock* system is an integrated system used in temperature control, distribution and heat management for underfloor heating systems.

This product solves all those problems arising from the use of autonomously managed components for the designer, installer and end user as it enables the use of a single system to communicate and manage the temperature control and heat distribution functions and capable of ensuring comfort for each individual room, enabling or disabling the heat generation system.

The nerve centre of the *RBM Kilma* system is the *Kilma Econblock* distribution unit which, along with the optional components supplied by RBM, is the heart of the power supply systems for heating systems with terminal elements mainly consisting of radiant underfloor panels.

The *RBM Kilma* control unit can be powered by a common wall-mounted boiler or by a more complex centralised distribution system;

It can have different management options, depending on the version taken into account.

USE

As can be seen, the *Econblock* heating management system is divided into two families, namely the "*Kilma Econblock in Brass*" and the "*Kilma Econblock in Polymer*" families

Unlike the *Kilma Evo* control units, it is only available in fixed version and adjustment (RF).

RBM Kilma Econblock adjusts the mixing unit of the control unit by means of a thermostatic head and therefore with a fixed value (the *Econblock* version with RM modulating adjustment control units is not available as for the *Evo* control units).

Furthermore, each family is divided into two subgroups, depending on whether or not the manifolds for the distribution of high temperature water are installed.

THE CHOICE

RBM Kilma Econblock it is a clearly simpler and cheaper system than *Kilma Evo RF/RM*.

Please note that in compliance with current Italian legislation on energy containment, the climate regulator (RM) is required in all those cases where the heat production system feeds multiple thermal zones and exceeds 35 KW of thermal power. *Econblock* control units can therefore be used within the limits of the provisions set forth by It. Presidential Decree 412/93, implementing law 10/91 in article 7 paragraph 2, which reads:

"In centralised heating systems used for room heating for multiple users, if the nominal power of the heat generator or the total power of the heat generators is equal to or greater than 35 Kw, a temperature control unit equipped with a programmer to adjust the room temperature on at least two levels to sealable values within 24 hours is required. The temperature control unit must be driven by a thermometric probe to detect the external temperature..."
Omissis..."

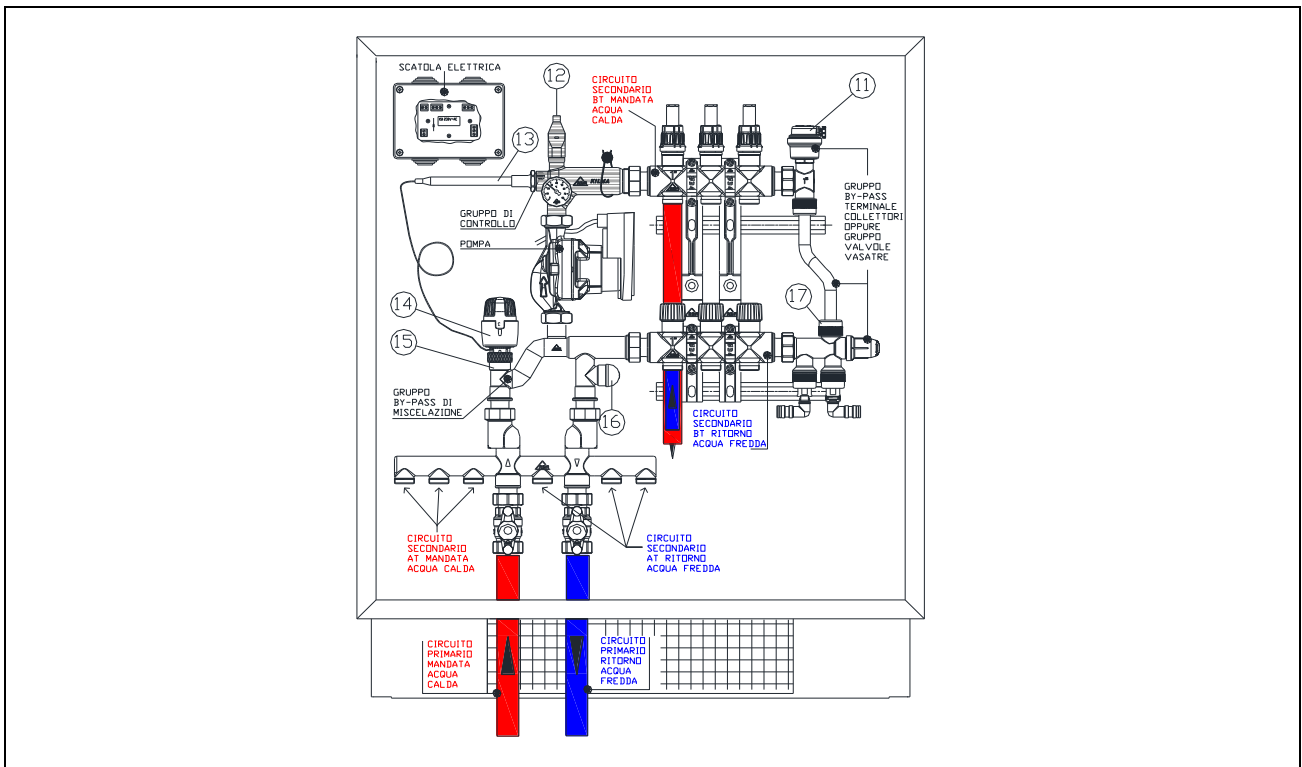

- Fixed Point control unit Econblock RF -

Electrical box

A box for the supply connections to the electricity supply mains, the pump, safety thermostat (12) to any room thermostat/timer-thermostat, or to the auxiliary micro-switch of the optional electro-thermal actuators. The box also permits the electrical connection of any burner start consensus.

The pump and the safety thermostat are already electrically wired; on the other hand the contact for the room thermostat is bridged (to insert a thermostat or another device, the bridge must be removed).

Control group

This is comprised of a temperature detection group with thermometer, a housing (embedded) for inserting the safety thermostat (12) and a housing for the TL50 (13) sensor.

The group permits the regulation of the mixing temperature and performs a safety action by guaranteeing that the flow temperature to the radiating panels never exceeds the limit value of 55°C+/- 3K: if this should happen, the safety thermostat interrupts the supply to the circulation device, which only restarts when the thermostat itself is reset (resetting is automatic when the temperature returns to acceptable values).

Mixing by-pass group

This is comprised of a thermostatic head (14) complete with sensor TL50 (13) and a hydraulic group comprised of a differential valve (10), a valve to which a thermostat can be fitted (15) and a lock-shield valve (16).

The mixing group permits the setting of the flow temperature to the secondary circuit via manual regulation of the thermostatic head. The temperature set in this way is maintained constant thanks to the retro action of the TL 60 sensor: this sensor in fact monitors the temperature of the thermostatic head, which consequently opens and closes the valve with thermostatic option.

Secondary LT (low Temperature) circuit

This is comprised of a multi-way manifold (from 3 to 13) complete with micrometric regulation lock-shields with a graduated knob, for the hot water flow to the radiating panels and of a multi-way manifold (from 3 to 13) complete with thermostatic option valves with manual knobs, for the return of the cold water from the radiating panels.

The thermostatic option valves can be servo-controlled via electro-thermal actuators (optional) for closing/opening the single circuits supplying the radiating panels.

HT (High Temperature) secondary circuit (Econblock RF-AT versions only)

Consisting of a three-way manifold to supply hot water to the high-temperature radiators and a three-way manifold for the return of cold water from high-temperature radiators (such as, for example, bathroom radiators or used for heating integration).

The H.T. circuit it is also available in the version with thermostatic lockshields and valves code 3792.003; (only available for Econblock BRASS control units).

The valves with thermostatic option can be servo-controlled by electrothermal actuators (optional) to close/open the individual circuits that feed the radiators.

Terminal by-pass group for manifolds

Comprised of a discharge valve with a red, holed cap (11), a shaped copper pipe and a two-way by-pass discharge group (17).

This group permits the by-pass for water circulation when all the low temperature ways are closed and the pump is still running. This group also permits system filling and air purging (see the relevant chapter).

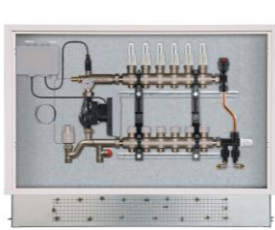

70X.XX.50

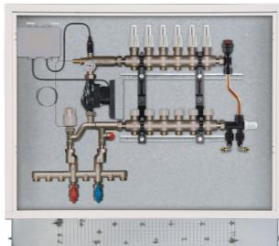

70X.XX.60

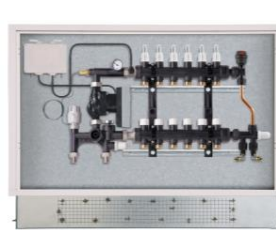

153X06.50

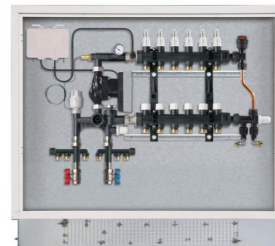

153X.06.70

Main performance

Description	Value	Measurement units
Primary thermal carrier fluid	Water (water + glycol 50%)	-
Circuit class	PN6	-
Power supply	230V 50Hz	
Maximum electrical power	200	W
Minimum electrical protection level	IP 40	-

Primary circuit connections	Brass Econblock	G 1/2" F
	Polymer Econblock	G 1/2" M
Low temperature circuit connections		G 3/4" Euroconus (M-UNI-EN-ISO 228)
High temperature circuit connections	Brass Econblock	G 3/4" Euroconus (M-UNI-EN-ISO 228)
	Polymer Econblock	W24,5 X 19F "Standard RBM"

Primary circuit inlet temperature	Brass Econblock	45÷80	°C
	Polymer Econblock	45÷70	°C
Optimum temperature for secondary circuit flow		40	°C
Max supply temperature of the high temperature circuit	Brass Econblock	80	°C
	Polymer Econblock	70	°C
Intervention temperature of the self-setting safety thermostat (max flow temperature to the secondary circuit)		55°C±3K	
Differential valve regulation		0÷60	kPa

Box for the electrical contacts for regulation to set-point

Description	Value
Power supply voltage	230V 50Hz
Electrical protection level in the box	IP42
Auxiliary outlet relay	10 A 230 V 50Hz (clean contact on switching)
Input (for circulator pump), controlled by the safety thermostat or eventually by the room thermostat	- (contact under voltage)

TL50 thermostatic head for regulation to set-point

Description	Value					Measurement units	
	1	2	3	4	5		
Thermostatic head position	☼	1	2	3	4	5	-
Flow temperature to the secondary circuit	25	28	34	40	46	52	°C
Maximum differential pressure						100	kPa
Bulb liquid composition						95% thermostatic ethyl acetate	

Pump Yonos Para RS 15/7 130 (cod. 1614.06.02)

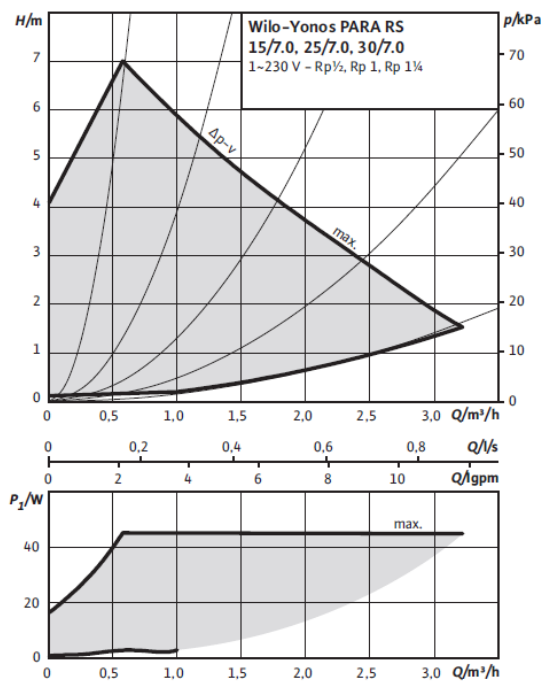
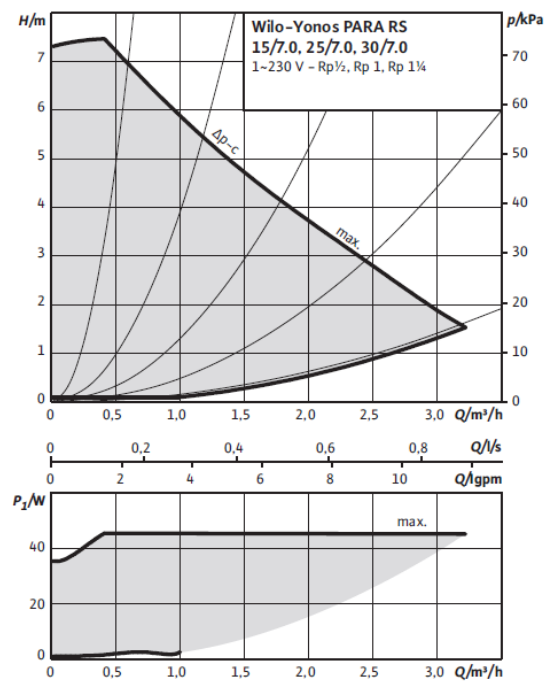

Description	Value		
Power supply	230 V 50/60 Hz		
	I [A]	P ₁ max [W]	Speed [rpm]
Maximum current I Maximum input power P ₁ max	0,03 – 0,44	3 - 45	800 - 4460
Degree of efficiency	EEI < 0,21		
Insulation class	Classe F		
Protection level	IPX4D		
Nominal pump pressure	PN6		

 $\Delta p-v$ (variable) $\Delta p-c$ (constant)

Perdita di carico: Corpo by-pass per centralina climatica. ECON-EVO

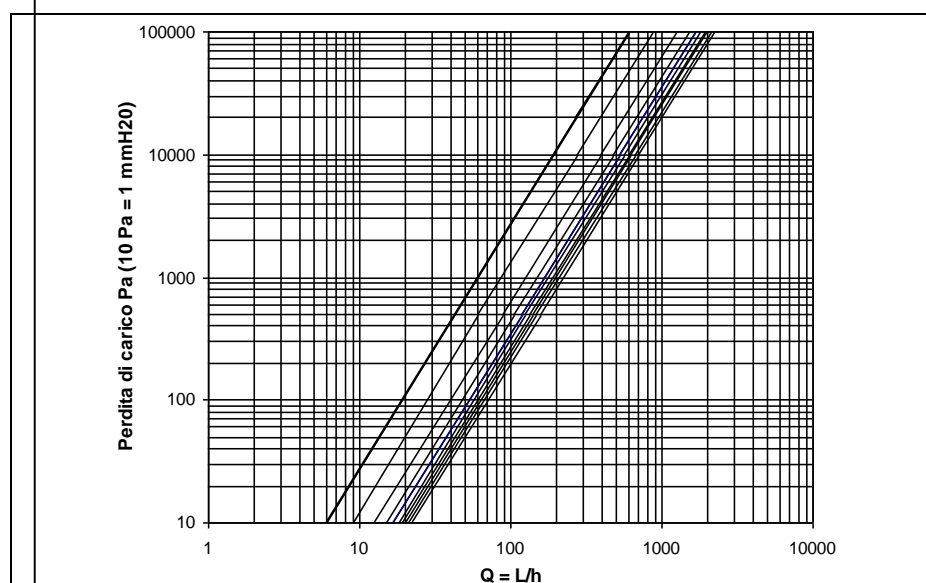

onblock



Lockschiel d revolution no.	Kw l/h
3/4	600
1	860
2	1250
3	1500
4	1650
5	1770
6	1900
7	1980
8	2100
9	2200





3-way distribution manifold for high temperatures with thermostatic option valves and regulation lock-shields (only for brass control unit Econblock RF cod. 70X.06.60)

Accessory description	Description of the features	Value	Code
 <p><u>Thermostatic option manifold with 3 distribution ways for high temperature</u> thermostatic option valve connections pre-arranged for NC electro-thermal actuator with 2 and 4 wires</p>	Thermostatic option valve connections	3	3792.003
	Regulation lock-shield option connections	3	
	Thermostatic valve connections	G 3/4" Euroconus	
	Regulation lock-shield connections	G 3/4" Euroconus	



KILMA ECONBLOCK CONTROL UNIT RANGE WITH THERMOSTATIC OPTION MANIFOLD

FIXED REGULATION	Code
	Brass RF-AT
	1701.06.60
	1702.06.60
	1703.06.60
	1704.06.60
	1705.06.60
	1706.06.60
	1707.06.60
	1708.06.60
1709.06.60	
1709.12.60	



Thermostat and chronothermostat

Description	Description of the features	Value	Code
 <p><u>Electromechanical room thermostat</u> <u>ON-OFF</u> <u>Wall mounted.</u></p>	Power supply	2 wire connection + 230 Vac for indicator light	386.00.22
	Operating temperature	5÷30°C	
	Thermal gradient	1K / 15 min	
	Thermal differential	0,8 K	
	Switching contact	16 (2,5) A 250 V	
 <p><u>Digital electronic room chronothermostat</u> <u>Wall mounted</u> <u>- ON/OFF</u> <u>- Summer/Winter</u> <u>- Manual/Automatic</u></p>	Power supply battery	2 x 1,5V AA Alcaline	2726.00.02
	Operating temperature	+5÷+35°C	
	Thermal differential	+ 0,4 K / -0,2 K	
 <p><u>Electronic room thermostat</u> <u>Recessed installation</u> <u>- Summer/Winter</u></p>	Power supply battery	2 x 1,5V AA Alcaline	1552.00.02 1552.00.12
	Operating temperature	5÷30°C	
	Accuracy	0,5 °C	
	Thermal differential	0,3 K	
	Electrical protection rating	IP 40 (front) IP 20 (rack)	
	Contact capacity	250 Vac 5(3) resistive load	
 <p><u>Digital electronic room chronothermostat</u> <u>Recessed installation</u> <u>- ON/OFF</u> <u>- Summer/Winter</u> <u>- Manual/Automatic</u></p>	Power supply battery	2 x 1,5V AA Alcaline	1553.00.02 1553.00.12
	Operating temperature (WINTER mode)	5÷30°C	
	Operating temperature (SUMMER mode)	15÷40°C	
	Accuracy	0,5 °C	
	Thermal differential	0,3 K	
	Electrical protection rating	IP 40 (front) IP 20 (rack)	
	Contact capacity	230 Vac 5(3) resistive load	

Attuatori elettrotermici

Descrizione accessorio	Descrizione proprietà	Valore	Codice
 <p><u>Thermo-electrically controlled servo motor for valve with thermostatic option, complete with valve body clamping ring nut and electric power cable – Normally closed</u></p>	Power supply	24/230V a 50/60Hz	306.00.02 306.00.12
	Consumption	2,5 W	
	Electrical protection rating (mounted on the horizontal line)	IP54	
	Max operating temperature	50°C	
 <p><u>Thermo-electrically controlled servo motor for valve with thermostatic option, complete with valve body clamping ring nut and electric power cable (with auxiliary microswitch) – Normally closed</u></p>	Opening time	~ 3min (version 230V) ~ 5min (version 24V)	306.00.42 306.00.52
	Stroke	4 mm	
	Streight on rod	110 N	
	Switch contact rating (if any)	5A a 230V, 50 Hz	

Hydraulic accessories

Accessory description	Description of the features	Value	Code
 <p><u>Tappe cieco per circuiti bassa temperatura e alta temperatura (solo centraline in OTTONE).</u> Corpo in ottone nichelato.</p>	Max temperature	110°C	240.05.00
	Max operating pressure	1000 kPa (10 bar)	
	Connection	Euroconus G 3/4 ¹ UNI-EN ISO 228	
 <p><u>Tappe cieco per circuiti alta temperatura (solo centraline in POLIMERO).</u> Corpo in ottone nichelato.</p>	Max temperature	110°C	42.00.00
	Max operating pressure	1000 kPa (10 bar)	
	Connection	W24,5 X 19F "Standard RBM"	

NOTES

Description of the symbols used

The symbols shown as follows, together with their wordings, indicate the risk potential deriving from failure to respect the prescription they are combined with.

**Caution.**

This warns that failure to observe the prescription leads to the risk of damage to the equipment comprising the mixing group.

**Danger, risk of electrical shocks.**

An instruction concerning electrical safety; failure to observe the same compromises electrical safety

**Danger.**

This indicates that failure to observe the prescription leads to a risk of damage to persons, animals and/or property.

Cautions before installation

The mixing group described in this technical sheet, distributes water at a temperature lower than boiling point at atmospheric pressure.

The mixing group must be connected to a hot water distribution system for room heating (*primary circuit*), within the limits of its performance and potential.

Before using the machine, carefully read the cautions contained here as they supply important indications about safe installation, use and maintenance.

Using the equipment for purposes other than the specified purpose is forbidden.

Kilma-Evo is supplied with hot water produced by an autonomous or centralised heating system: check that the operating conditions are compatible with the operating characteristics shown in the "Technical characteristics" and "Fluid dynamic characteristics" items. Also check that the electrical supply is suitably protected.

(Remember that the installation must only be performed by professionally specialised personnel, qualified according to the law of 5 March 1990 no. 46, respecting current legislation and regulations).



During the electrical and hydraulic connections, ensure that both the water supply mains and the electrical power supply are isolated.



Before installation, ensure that the electrical system, hot water supply system (*primary circuit*), low temperature heating distribution system (*secondary circuit*) and the hot temperature circuit (if present) have been correctly executed by requesting their respective "Conformity Declarations".

General cautions for safe use

Poor installation can cause harm to persons, animals or property: the constructor is not liable for damage caused by installation errors, failure to observe these instructions or from improper use of the equipment..

Also observe the instruction listed as follows:

- Do not wet the equipment and do not install it without protection, in humid environments or close to jets or sprays of water or other liquids.
- Given the presence of hot fluids, do not place paper and/or plastic coated objects on the equipment.



The packaging (plastic bags, expanded polystyrene, etc.) must not be left within the reach of children as it is a potential source of danger



Children and incapable persons must be prevented from using the command and control equipment, as well as from using the entire equipment.

Given the presence of hot fluids, contact burns may be provoked: before performing any maintenance operations, suitably cool the internal components, by closing the interception valves of the primary water circuit and by letting the fluid circulate in the secondary circuit. Also adopt all the protective measures necessary to reduce the risk of injury.



Any intervention on the electric and/or hydraulic circuit concerning ordinary or extraordinary maintenance operations, must only be performed by professionally specialised personnel qualified according to the law of 5 March 1990 no. 46, respecting current legislation and regulations: do not intervene personally.

For better system operation, we highly recommend following the relative maintenance indications, and if any machine parts have to be replaced, using original spare parts supplied by the constructor



Before performing any cleaning or maintenance operation, respect the following prescriptions:

- The power supply must be isolated.
- It is very dangerous to operate the machine without any one of its components, especially if they are accident protection elements or mechanical and/or electrical safety devices.
- Cleaning, oiling or greasing parts and elements of the machine in motion by hand is forbidden.
- Performing any maintenance, regulation or adjustment of the parts of bodies in motion is forbidden.
- The mixer group must not be started for any reason at all by non-qualified persons, after checking the conclusion of the maintenance operations.



In the event of a fault, or poor equipment operation, switch it off, close the interception valves of the primary circuit and isolate the electrical power supply.

Do not tamper with the equipment.

For reactivation and/or repair, contact the installation company of the thermal system which issued the conformity declaration, or alternatively, contact an installation company you trust if there are no warranty constraints.



Kilma-Evo is exempt from I.S.P.E.S.L. inspection obligations, as its primary circuit is supplied with water at a temperature below boiling point at atmospheric pressure.
 The mixer group is not subject to the maintenance obligations of "thermal systems" falling within the definition of article 1 paragraph 1f of D.P.R. no. 412/93, as foreseen by article 11 of D.P.R. no. 412/93, as it is not a steam generator.

Identification of the product and the constructor

Correct product identification is very important over time: this allows the constructor the possibility of giving the customer the technical information requested in a rapid and certain manner and it facilitates spare parts management.

The means of identification is the plate fitted to all Kilma Econblock models.

As clearly visible in the figure below (facsimile of the product identification plate) the plate contains the information to report to the installation company, or in the case of need, to the constructor:

RBM S.p.A. – via S.Giuseppe, 1 – 25075 Nave (BS) Tel.: +039-030-25.37.211, Fax: +039-030-25.31.798.

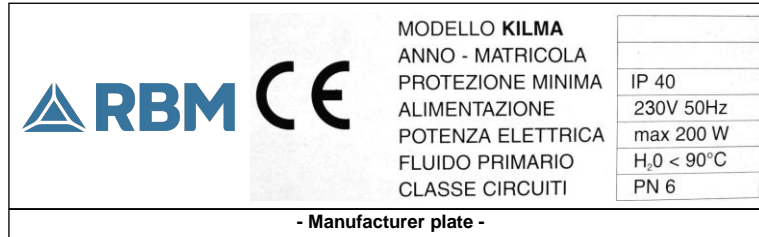

This is the sole plate recognised by the constructor as a means of product identification. The means necessary for machine identification must not therefore be tampered with, ruined or removed.

3 INSTALLATION – MASONRY ASSISTANCE AND DIMENSIONAL CHARACTERISTICS CASSETTE DI CONTENIMENTO CENTRALINE

Kilma Econblock distribution control units require several simple masonry assistance operations in order to insert the containment box into the wall.

The containment box

Kilma Econblock range distribution control units are contained in a galvanised, painted, metal box for flush fitting in walls. The inspection cover, inserted in an adjustable external frame, can be completely removed and has a latch for closing. Its external dimensions are those of the perimeter frame of the box. The containment boxes are supplied in 6 standard lengths, adjustable in height and depth.

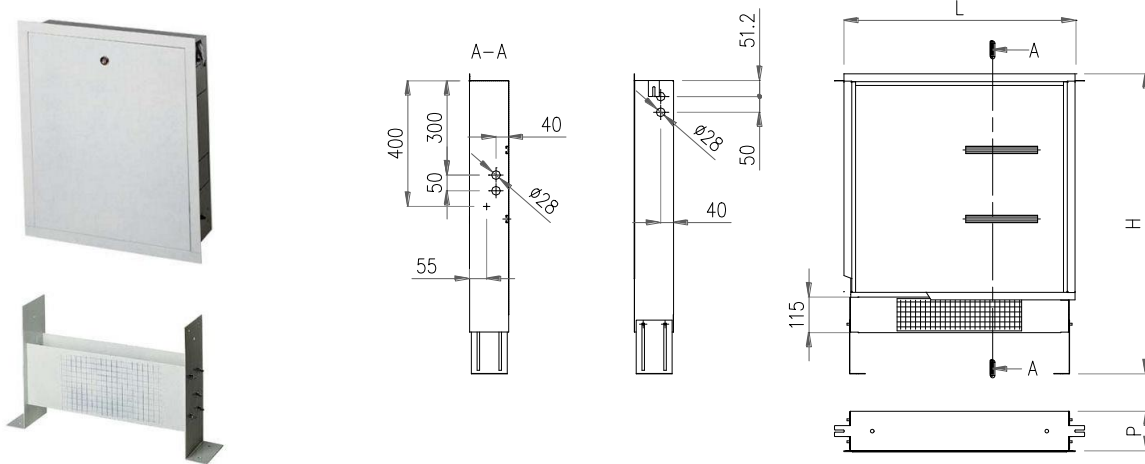

Control unit Kilma Econblock	Depth P [mm]	Height H [mm]	Ways number L.T.									Length L [mm]	
			3	4	5	6	7	8	9	10	11		12
Kilma Econblock RF 70X.XX.50 153X.06.50	110÷150	680-815											
Kilma Econblock RF-AT 70X.XX.60 153X.06.70	125÷165	800-935	700	800	900	1000	1100	1200					

Positioning and finishing

Insert the box in the opening made in the wall, taking care to rest the support feet directly on the rough floor slab surface.

Adjust the height of the box in function to the height of the future radiating system: generally, in order to permit correct inspection hatch opening, and given the presence of the perimeter skirting board, the height adjustment must be made so that the bottom of the box coincides with the level of the finished floor.

If the box is inserted in a wall still to be plastered, position it so that it protrudes on the inspection hatch side by at least 10 mm. to permit the correct flush application of the plasterwork.

Before completely walling in, also remember to guarantee the passage of the conduits for the electrical connections (see the "Installation – electrical connections" section).

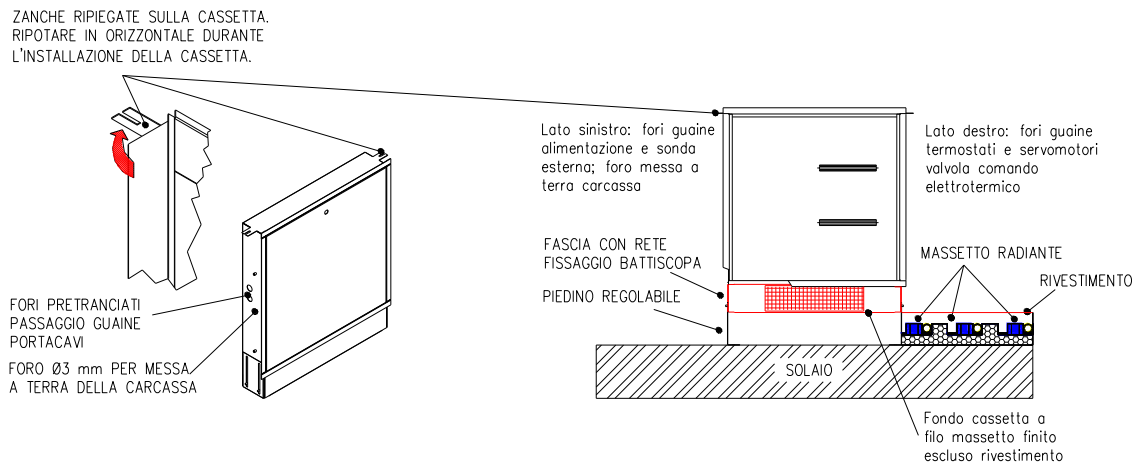



Figure 1 (on top):
Scheme of the passage of the cable holder sleeves through the existing box holes.

Figure 2 (on top):
Scheme of positioning of the box with reference to the screed

After positioning the box, we recommend securing it inside the niche in the wall, by applying quick-setting cement.

 We advise against removing the protective plastic film from the perimeter frame and from the inspection cover to prevent deterioration of the surface coating.

Plaster all round the perimeter and on the low front band. As soon as the plaster hardens, the perimeter frame supporting the inspection cover, can be adjusted and secured (to the vertical elements of the box). Remove the protective plastic film completely at the end of the installation and start-up works (chapters 3 and 4).

Cautions before installation



The installation must only be performed by *professionally specialised personnel*, qualified according to the law of 5 March 1990 no. 46, respecting current legislation and regulations.

Before connecting Kilma-Evo, *carefully wash all the system pipes – incoming and outgoing – to eliminate threading, welding and solvent residues possibly present in the various components of the heating circuit.*

In order to protect the valve seats from impurities in the piping, we recommend fitting a common Y filter with a removable metallic element to the primary circuit.

Main plumbing components CONTROL UNIT ECONBLOCK





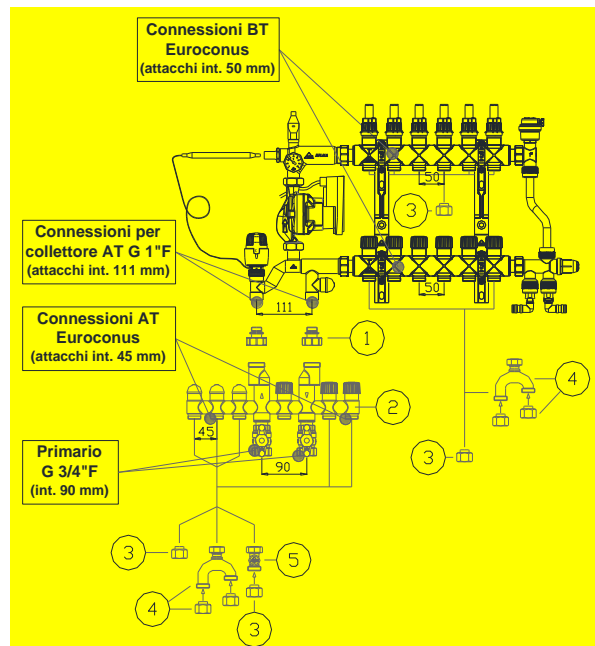



Kilma Econblock versions can be fitted with a series of optional **hydraulic accessories** selected from time to time, for the specific application, by the designer of the heating system or by the installer.

The diagrams below highlight the main connection options to the systems.



KILMA ECONBLOCK BRASS control unit

High temperature/ Low temperatur
(M G3/4" Euroconus)

Pos.	Description	Pos.	Description
1	 3943.003 Joint fitting	4	 311.05.00 + 71.XX.00 Y-shaped fitting + fitting
2	 4236.003 3 way manifold for H.T. 3792.003 3 way manifold kit with thermostatic valves and lockshields	5	 267.05.50 Thermostatic valve (for standard H.T.manifold)
3	 217.XX.00 Compression fitting for polyethylene pipe	5	 215.05.50 Micrometric setting lockshield (for standard H.T.manifold)
3	 224.XX.00 Compression fitting for multilayer pipe	-	 1213.005 Pressure control manometer
3	 240.05.00 Blind cap (for unused high/low temp. circuits)		

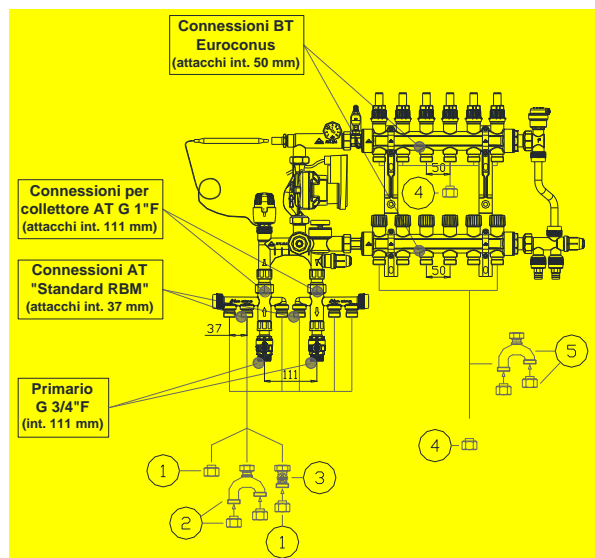

KILMA ECONBLOCK POLYMER control unit

High temperature (RBM standard M connection)
Low temperature (M G3/4" Euroconus)

Pos.	High temperature (RBM standard M connection)	Pos.	Low temperature (G3/4" Euroconus)
1	 71.XX.00 Compression fitting for polyethylene pipe	4	 217.XX.00 Compression fitting for polyethylene pipe
1	 70.XX.00 Compression fitting for multilayer pipe	4	 224.XX.00 Compression fitting for multilayer pipe
1	 41.XX.00 Compression fitting for copper pipe	4	 240.05.00 Blind cap (for unused low temp. circuits)
1	 42.00.00 Blind cap (for unused high temp. circuits)	5	 311.05.00 + 71.XX.00 Y-shaped fitting + fitting
2	 311.00.00 + 71.12.00 Y-shaped fitting + fitting for Ø12 pipe	-	 1213.005 Pressure control manometer
3	 556.00.00 Valve with thermostatic option		
3	 106.00.00 Micrometric setting lockshield		

**ATTENTION:**

Clamping of the fitting on polymer contTightening of junction pipe fittings, polymer control units, with max. values 30Nm.

Tightening of control unit plastic components with max. values 15±20Nm.

Cautions before installation



The installation must only be performed by *professionally specialised personnel*, qualified according to the law of 5 March 1990 no. 46, respecting current legislation and regulations.



When connecting the electrical wires, ensure that the electrical power supply is isolated.

Electrical pre-arrangements



A series of push-through blanks are present on the sides of the metal containment box, which permit the passage of the cable conduits, after removing the blanks.

In particular, before completing the walling, it is necessary to ensure the protection of the conduits for:

- 230V + Earth mains power supply cable
- Cable for eventual connection to the boiler
- External sensor connection cable (only for Kilma –Evo RM)

Connection cable for possible thermostats/timer-thermostats, servo-motors etc.

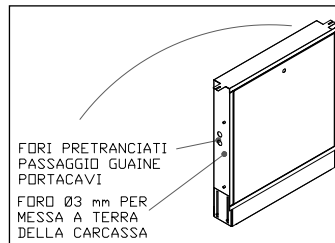

The cables are inserted into flexible conduits or dedicated channelling separated from the electrical system so as to avoid interference problems generated by other equipment without the CE mark.

With the Kilma-Evo RM models we recommend arranging the passage of the power supply connection cables through a separate conduit to the one used for the connection cables of the external sensor and the flow.



The cable must be inserted into the piping without tearing, so as not to damage the internal conductors. Also, during installation, take care not to trample on the cable or place weights on it, so as not to alter the existing space between the internal conductors.

In order to guarantee the continuity of the electrical protection of the entire system, we recommend connecting the passage conduits directly to the electrical junction boxes of the command and control equipment, preferably using the specially designed grommets (Kilma-Evo RM model) or the grommets (Kilma-Evo RF) already fitted to the electrical boxes themselves.

230V power supply line



The terminal blocks in the electrical section of Kilma-Evo must be connected electrically to a suitably protected single phase 230V power supply mains.



When making the connection, respect the Phase-Neutral polarity, as indicated in the Kilma-Evo RF or Kilma-Evo RM electrical diagrams (depending on the product purchased).



We advise that the electrical safety of Kilma-Econblock is only achieved when it is connected to an efficient earth system, executed according to the current regulations disciplining system safety.

Kilma Econblock electric scheme

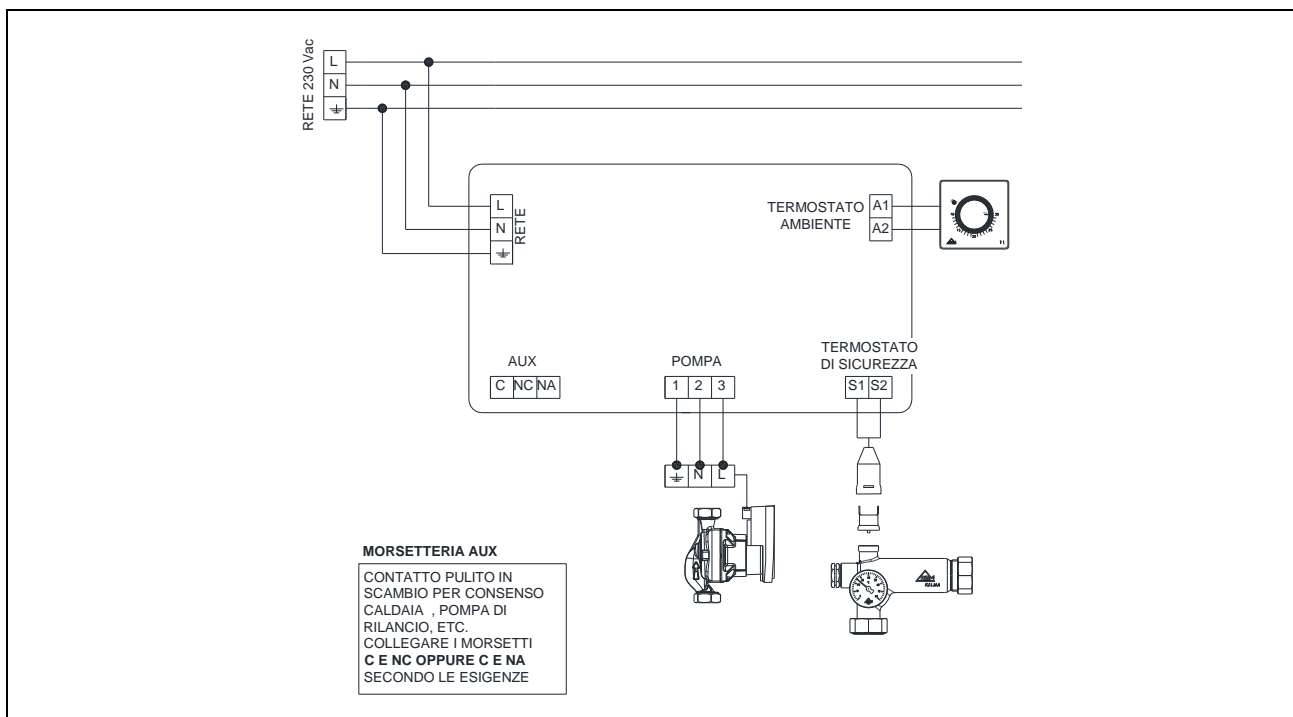

Thermostat contacts operation

In order for thermal energy to be supplied, the following conditions are necessary: the safety thermostat closes terminals S1 and S2, while the room thermostat closes terminals A1 and A2: when terminals S1 and S2 or terminals A1 and A2 are open, thermal energy can no longer be supplied.

Use of the auxiliary contact for boiler consensus

The Kilma-Econblock system has a "clean" contact called Auxiliary for boiler start consensus (or for the restart pump) to interrupt the thermal energy supply when the system has satisfied all demands.

Kilma-Econblock RF (high temperature circuit present) use

For efficacious use of the auxiliary contact, it is necessary to fit the thermostatic option valves (cod. 556.00.00) on the high temperature circuit manifolds.

The Kilma-Evo configuration must also foresee the use of the optional NC electro-thermal actuators, cod. 306.00.X2, both on the thermostatic option valves of the secondary circuit and on those of the high temperature circuit.

When the zones served by the floor system are satisfied, and it is still necessary to heat high temperature zones (such as bathrooms, if managed with very high room temperatures), the Auxiliary contact outlet is deactivated (the NA type contact opens, while the NC type closes).

The micro-switch (of the actuators fitted to the high temperature circuit) is still active however: the primary boiler circuit is maintained in operation, while the mixing system for low temperature supply is deactivated.

When the system has satisfied all demands, the actuator micro-switch fitted to the high temperature circuit is also deactivated and the boiler switches off.

Kilma-Econblock (no high temperature circuit present) use

If the condition arises whereby all the thermostatic option valves are closed occurs, (via the optional NC electro-thermal actuators cod. 306.00.X2), the mixing group is completely "Closed", the pump is at a standstill and the Auxiliary outlet contact is deactivated: the NA contact opens and the NC contact closes.

Room thermostats/timer-thermostats

The figures below show the possible installation prescriptions.

The minimum installation height must be 1.5 metres from the floor and the distance from the adjoining wall must not be less than 0.5 metres, to avoid probable areas of air stagnation.

The room thermostat/timer-thermostat must be positioned so that it is accessible to persons for inspection and regulation.

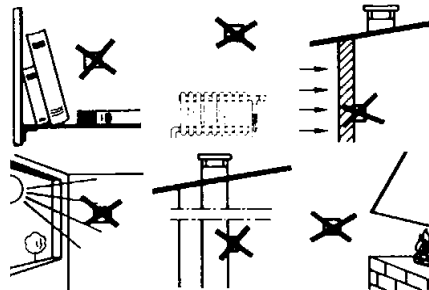
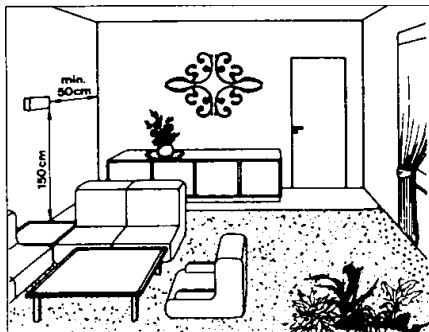

It is also necessary for the reading to be free from direct or indirect disturbances. Consequently, it is normally necessary to exclude the following installations:

- Close to sources of heat
- On an internal wall receiving sunlight
- On a wall in direct contact with the outside
- Close to doors and windows
- Segregated or obscured by furnishing items (furniture, books, etc.)

Cautions before the initial start-up

Check and make certain that:

- The plate data matches the data of the supply networks (boiler primary circuit)
- The installation conforms to current regulations
- The conditions exist for the regular endorsement of the Guarantee certificate

System filling procedure (follow the instructions on the next page)

After making all the connections properly (electrical and hydraulic) the water supply mains can be turned back on, and the system can be filled.

As follows, we supply an example of the procedures to follow for the filling operations of the Kilma-Evo RF (1 and 3) and of the Kilma-Evo RM (1 and 3) and of the circuits connected to them. For the numbered references, use the enclosed schemes on the next page.

A) Filling low temperature circuits

- Ensure that the electrical parts are disconnected
- Close all the thermostatic option valves (1 indicates the first thermostatic option valve) located on the manifold (clockwise knob rotation)
- Close all the lock-shield valves (2 indicates the first lock-shield valve) located on the manifold (knob release by turning clockwise)
- Close the lock-shield valve (3) of the bypass group (remove the cap and turn the screw head clockwise with a Allen key – CH 5).
- Close the lock-shield valve (4) of the mixer group (remove the cap and turn the screw head clockwise with a Allen key – CH 5).

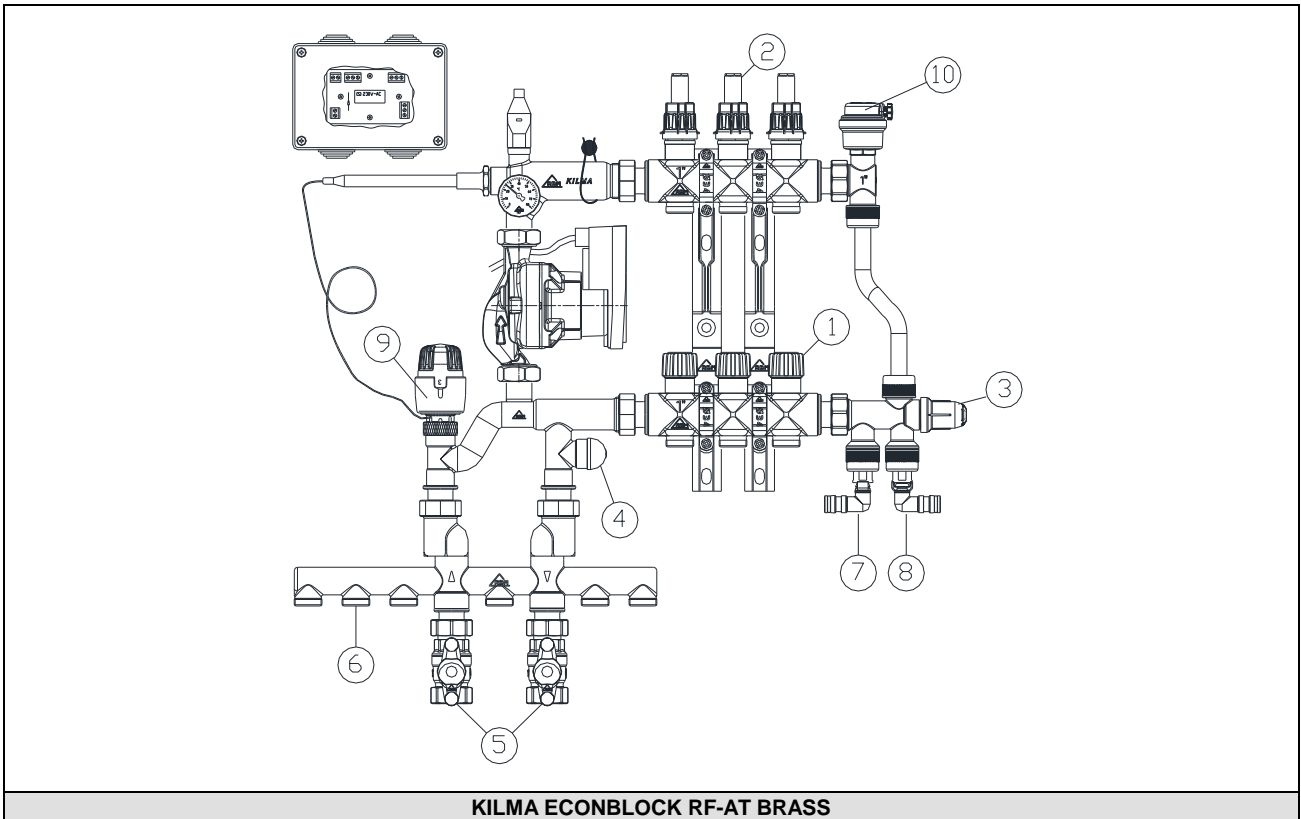

- Close the ball valves (5)
- Close any circuits (6) connected to the high temperature (radiators, bathroom heater elements, etc.)
- Insert a plastic pipe connected to a valve connected to the water mains, into the connector (8) of the bypass group
- Insert a plastic pipe connected to a drain into the connector (7) of the bypass group
- Open the shut-off connected to the connector (8) all the way (anticlockwise rotation with a CH18 Allen key)
- Open the thermostatic option valve (1) and the first lock-shield valve (2)
- Begin to fill the system by opening the valve connected to the water mains
- Fill the entire circuit keeping the drain valve connected to the connection (7) open (anticlockwise rotation with spanner CH 18), until all the air in the floor circuit is completely eliminated*
- Re-close the valve (1) and the lock-shield valve (2)
- Repeat this operation for the remaining circuits on the low pressure manifold

B) High temperature circuit filling for Kilma-Econblock

- Remove thermostatic head TL50 (9)
- Keeping all the thermostatic option valves and all the lock-shield valves of low temperature circuits closed, open and fill any high temperature circuits (6)
- Fill the entire circuit keeping the drain valve (8) open and the air purging valves of the single heating elements open until all the air contained in the circuit is completely expelled*.
- Close the drain valves connected to connectors (7) and (8) of the bypass group, re-open all the thermostatic option valves and all the lock-shield valves of the low temperature circuits, regulate the bypass group (3), the mixer group (4) and refit the head TL50 (9).

Putting under pressure (see also standard UNI-EN 1264-4:2003)

On concluding the circuit filling operations, perform the pressurisation of KILMA EVO (via the filling system provided with the boiler) and the circuits supplied by the same.

- Raise the system pressure to 1.5 times the design pre-load value (but do not exceed the calibration pressure of the safety valve on the boiler)
- After around 2 hours, check that there are no leaks or visible blow-bys and that the pressure has remained about the same
- Close the interception valves (5) to prevent the intervention of the boiler safety valve
- With the aid of a manual filling pump, connected to KILMA Econblock via a connector (7) or (8), raise the pressure to 600 kPa (6 bar)
- Leave the circuit pressurised for the entire duration of laying and curing of the floor slab constituting the radiating floor.



To insert anti-freeze additives and for the specific prescriptions concerning the floor system circuits, consult the specific use and maintenance manual and the installation instructions.

* When the outlet water flow is continuous and free of air bubbles from the shutter connected to the hose connection (7), air is fully removed.

Cautions before start-up

Check and ensure that:

- The plate data matches that of the electrical power supply mains
- The installation conforms to current regulations
- The conditions exist for the regular endorsement of the guarantee certificate

Procedure to follow to permit starting-up the Kilma RF system

Once all the connections (hydraulic and electrical) have been correctly made, and once the hydraulic system has been put into operation, there are no particular prescriptions to observe: in order to start-up the system, re-activate the electrical power supply mains.

If on the other hand thermostats/timer-thermostats have been fitted (optional components) so as to permit also the regulation of room temperature, consult the instructions of the component or components chosen in order to proceed with the electrical start-up.



Before performing any maintenance operation, make sure that the water and electrical supplies are isolated.

We also remind that maintenance operations must only be performed with the system at a standstill and cold, exclusively by professionally specialised personnel, qualified according to the law of 5 March 1990 no. 46, respecting current legislation and regulations.

For the first thermal season, we advise a monthly control; successively, above all when the phenomenon of the formation of "air" in the pipes and generally in the heating system has been eliminated, the controls can take place quarterly. When maintaining your heat generator it is advisable to have your maintenance personnel check the conservation and operation of the Kilma-Evo system, always remembering to have this technical documentation to hand.

On the next page we indicate the main maintenance and management aspects concerning Kilma-Econblock USE.

Periodical controls

- Check for the presence of dripping or lime scale encrustation at all the threaded joints. If any such signs are found replace the seal gaskets after carefully cleaning the seats.
- Check the filling pressure of the heating system according to the designer's and/or installer's instructions. Without this information, check that the system fill pressure (measured with the system cold and switched off), is no lower than the following values:
 - ☞ 100 KPa (in other words 1 bar – around 10 m H₂O) for systems in which the boiler is located on the same floor as the heating system
 - ☞ 100 KPa + 10 KPa for every meter of height difference between the boiler and the system in cases where the boiler is located in a room beneath the system to serve (e.g. if the height difference is 3 metres, the fill pressure must not be less than 130 KPa)
- Periodically the drain valves must be slightly opened (anticlockwise rotation using CH18 spanner at the points indicated in the figures below) in order to let the fluid out for a moment. This measure is necessary to prevent the formation of material over time which would compromise the good operation of the drain valves and thus also of the entire system.
- At the end of this operation, re-close the open drain valves and restore the system pressure of the entire system.



- Periodically, specialised technical maintenance personnel (qualified according to the law of 5 March 1990 no. 46) must check the condition of the non-return valves 1, 2, and 3 (non-return valve 3 is inserted in the HT ways, and is therefore only present in the Kilma-Evo RF1-2 and RM1-2 versions).

If necessary, remove any encrustation and/or foreign bodies; if this is insufficient to restore optimum system conditions, replace the non-return valves (cod. Valve 3000.005; snap ring 3227.005).

The control above is necessary above all when reduced system performance is noticed (for example, when the system has difficulty in maintaining the room temperature previously easily reached, or when the thermometers (inserted in the control group and in the water mixing group) indicate temperatures much lower than the mixing temperature (for Kilma-Evo RF, see the setting on the thermostatic head, while for Kilma-Evo RM, the mixing temperature indication is shown on the display).

Circuit cleaning

As indicated in chapter 3 (Installation – Water connections) we recommend providing the primary circuit with a common Y type filter with a removable metal braid to protect the valve seats from impurities present in the pipes.

When performing annual boiler maintenance, clean the internal cage and before replacing it, check the condition of the seal seat gasket of the plug and replace it if necessary.



Before use, check and maintain Kilma-Evo; consult chapter 3 (Installation – General cautions) of this manual.

Also check the existence of any boiler use and maintenance limitations, as well as the recommendations issued by the installer when installing the floor heating system..

APPENDIX

KILMA ECONBLOCK SERIES CONTROL UNIT ELECTRICAL DIAGRAMS

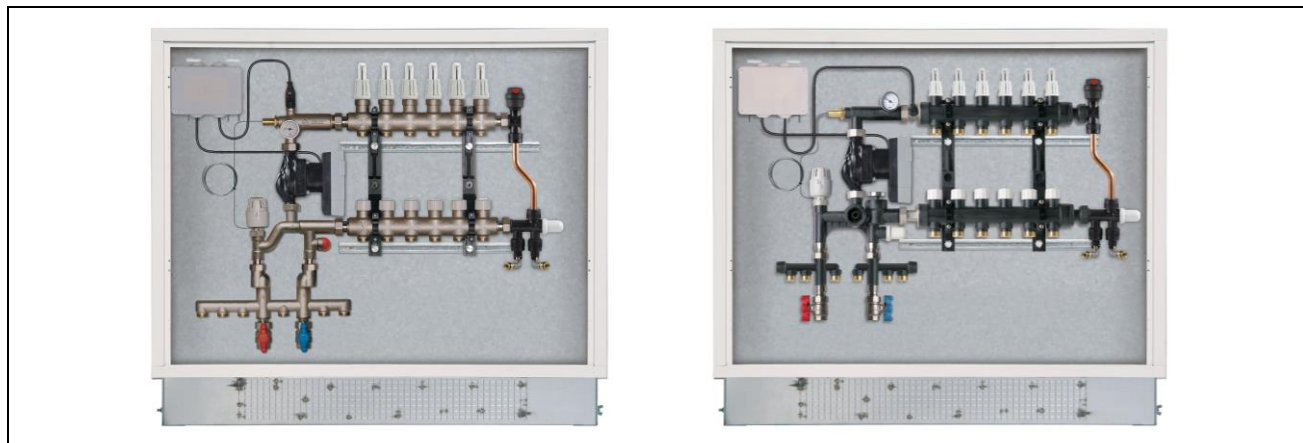

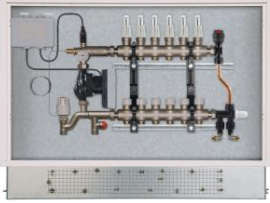
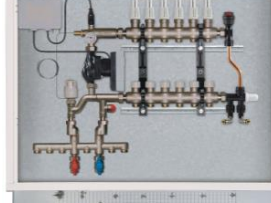
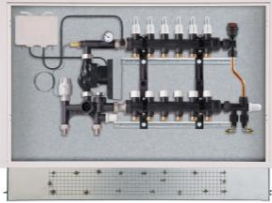
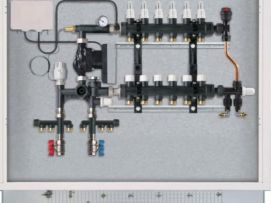
KILMA ECONBLOCK RF			
BRASS Control unit		POLYMER Control unit	
RF	RF-AT	RF	RF-AT
			
70X.06.50	70X.06.60	153X.06.50	153X.06.70

PRODUCTION RANGE

FIXED REGULATION	No. of high temperature ways*	Code				No. of low temperature ways**
		High-low temperature water distribution		Only low temperature water distribution		
		RF-AT BRASS	RF-AT POLYMER	RF BRASS	RF POLYMER	
3 + 3		701.06.60	1531.06.70	701.06.50	1531.06.50	3 + 3
		702.06.60	1532.06.70	702.06.50	1532.06.50	4 + 4
		703.06.60	1533.06.70	703.06.50	1533.06.50	5 + 5
		704.06.60	1534.06.70	704.06.50	1534.06.50	6 + 6
		705.06.60	1535.06.70	705.06.50	1535.06.50	7 + 7
		706.06.60	1536.06.70	706.06.50	1536.06.50	8 + 8
		707.06.60	1537.06.70	707.06.50	1537.06.50	9 + 9
		708.06.60	1538.06.70	708.06.50	1538.06.50	10 + 10
		709.06.60	1539.06.70	709.06.50	1539.06.50	11 + 11
		709.12.60	1540.06.70	709.12.50	1540.06.50	12 + 12
	Manifold H.T.	Yes	Yes	No	No	

DESCRIPTION

Electrical diagrams for KILMA EVO RM1, RM2, RM3, RM4 control units with three distribution ways for high temperature with thermostatic option valves and regulation lock-shield valves and in the variation with thermostatic actuators installed.

Electrical connections of the Kilma Econblock series RF series control unit with fixed adjustment, with junction box (code 2516.003).

The installation must only be carried out by professionally qualified personnel, authorised according to the law of 5 March 1990 No.46, in compliance with applicable laws and regulations.



During the electrical and hydraulic connections, make sure that both the water supply line and the power supply mains have been disconnected.

The electrical connections shown have the sole purpose of supplying the technician with a rapid guide for connecting the entire system electrically. The electrical connections shown are not binding and do not therefore represent the performance limits of the components.

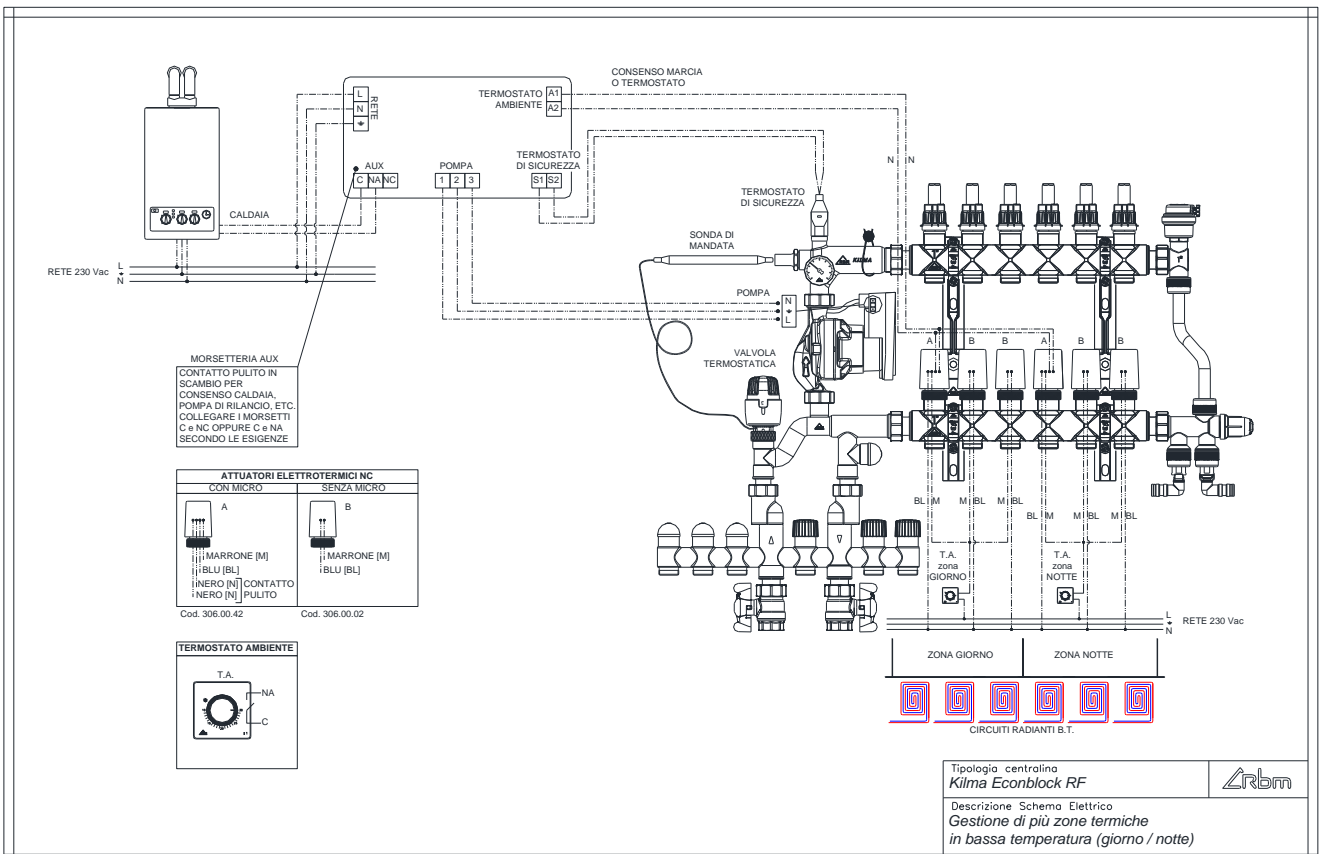
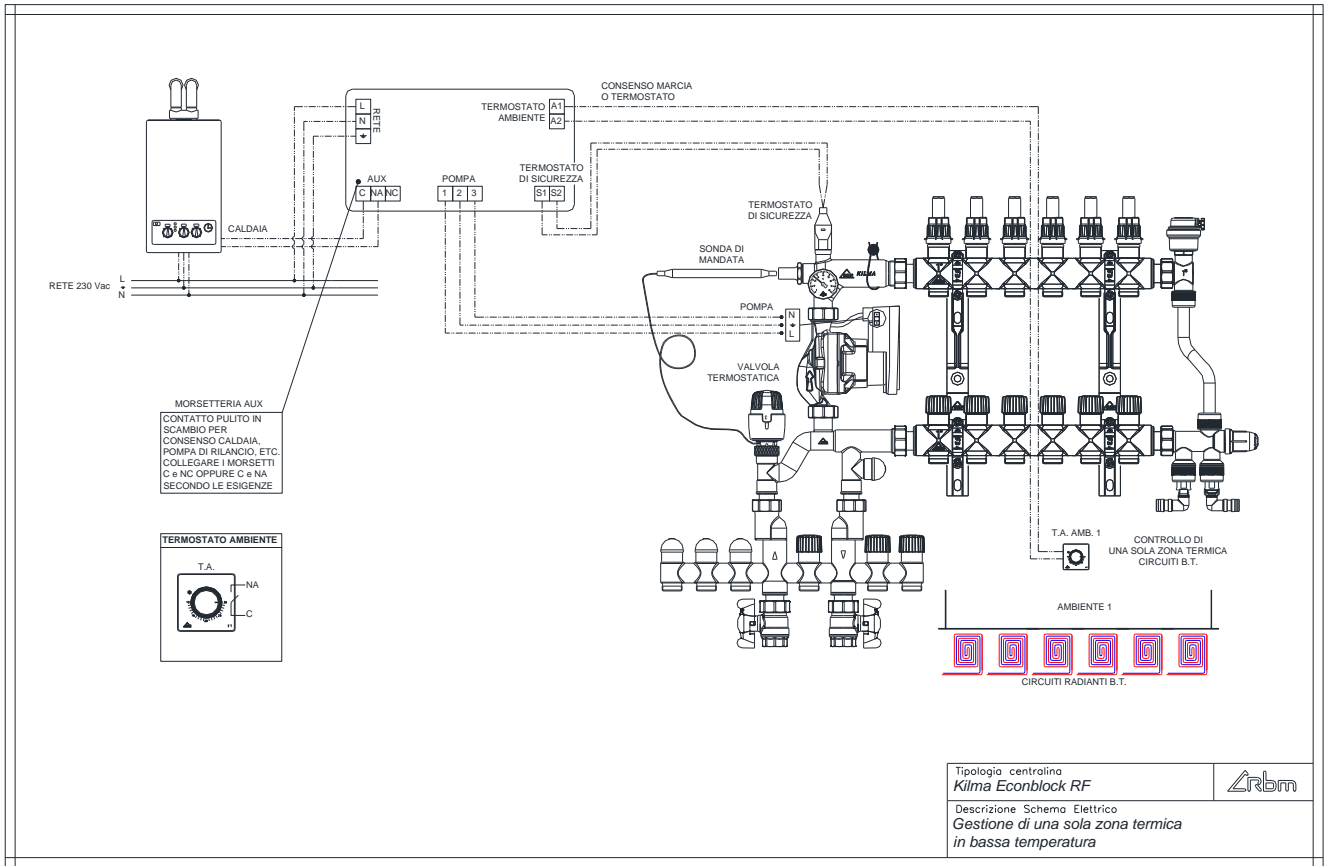

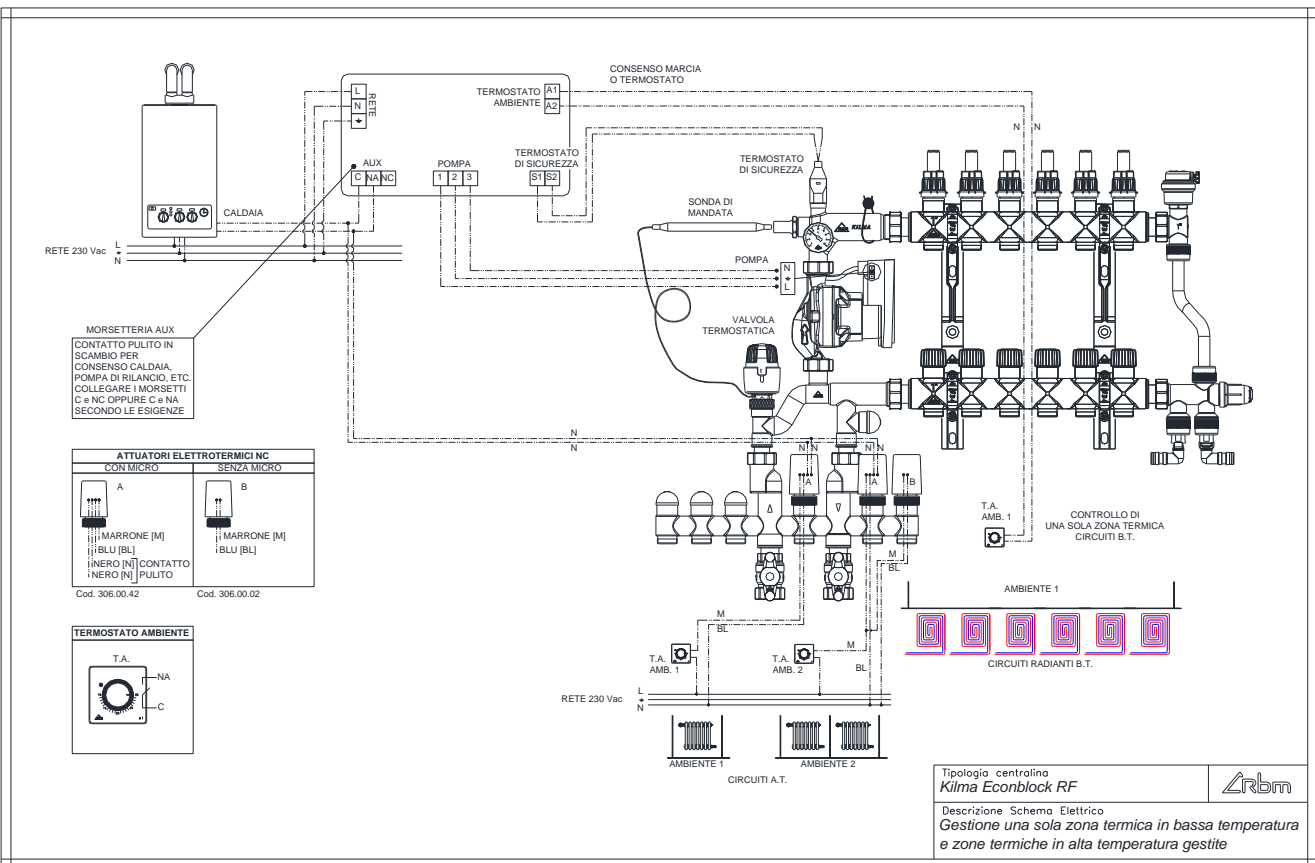
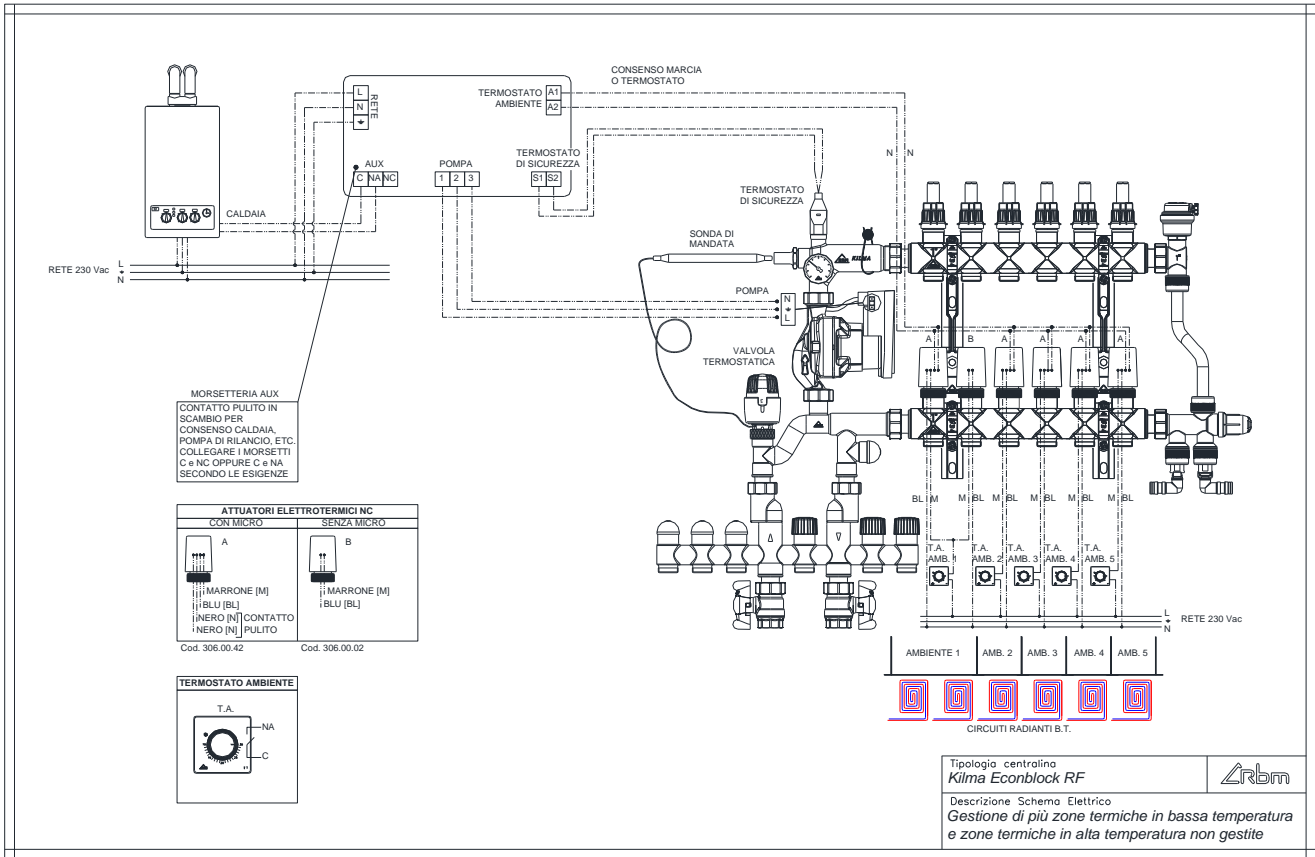

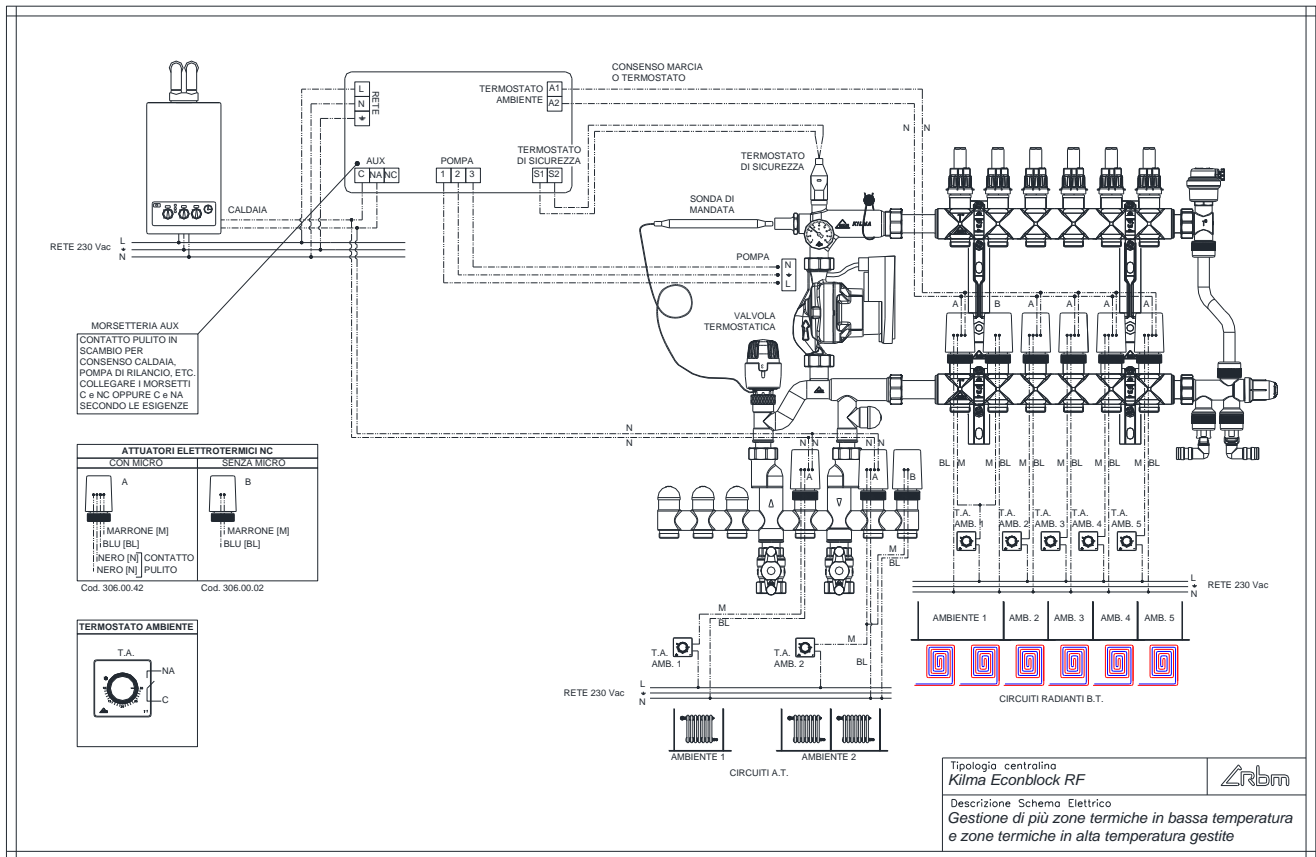

RBM spa reserves the right to make improvements and changes to the described products and to the corresponding technical data at any time and without prior notice.



The information and images contained in this document are intended to be provided for information purposes only and are not binding. In any case, these information can not exempt the user from strictly following the regulations in force and the good practice rules.

RBM Spa
 Via S.Giuseppe, 1
 25075 Nave (Brescia) Italy
 Tel. 030-2537211
 Fax 030-2531798
 info@rbm.eu - www.rbm.eu